

(925) 422-4105 / (925) 422-4667 (fax) / seppala1@llnl.gov

Date: March 6, 2003

Pages: 27 total

To: Larry Daggert, NOAO
Tel: (520) 318-8361
Cc: Chuck Claver, NOAO

Subject: LSST 4 degree FOV Optical Design Study – Final Report

Dear Larry and Chuck,

This is my report for the current optical design study. The main goal is to understand the effects of increasing the field of view to 4 degrees for the LSST project.

Designs have been completed for both a 3.5 and 4.0 degree field of view since satisfactory images were not possible for the larger field. One of the main problems is lack of chromatic correction as the field angle is increased. The lens thicknesses of the positive lenses are forced to increase as the field goes from 3.0 to 4.0 degrees. Larger lens thicknesses require shorter lens focal lengths, to compensate for chromatic aberrations that further aggravate the thickness of glass. Edge thicknesses should also be increased as the diameter of the positive lenses and spectral filters get larger to ensure a fair comparison between designs.

Ground rules

The thickness of the negative corrector lens L_2 , for all designs, was increased from 2.0 cm to 3.0 cm to lessen the risk of breakage during fabrication. The edge thicknesses of the positive lenses for the 3.0 degree design were 2.0 cm for L_1 and 1.0 cm for L_3 . The edge thicknesses for each of the positive lenses and spectral filters are increased in proportion to the field angle, going to 2.67 cm for L_1 and 1.33 cm for L_3 for the 4.0 degree field. This edge thickness scaling is roughly proportional to the diameter of the elements for both lens L_3 and the spectral filter because of the nearness of the detector. The edge thickness of lens L_1 increases faster than the diameter for this scaling, but this effect is probably reasonable because of the very large size of 1.5 m in diameter.

Design with 4.0 degree field

The image sizes were rather large and all possible degrees of freedom were used to try to control them. The spectral filters were allowed to vary from the ideal shape of concentric about the chief ray (radius of ~4 m), important to minimize angle-of-incidence effects across the field. Each filter became a weak meniscus lens, with the base radius varying from 2.2 m for the U band to 7.0 m for the z band. Image sizes for the V, R, I and Z spectral bands are

generally less than 0.4 arc-seconds across the field. The images at the U and B band are less than 0.8 and 0.6 arc-seconds, respectively.

Design with 3.5 degree field

The images sizes are better for a field angle of 3.5 degrees. The spectral filters can still be concentric about the chief ray. The second surface of the filter has different radii of curvature for each filter, making the filter a very weak meniscus lens. The thicknesses of the filters also are varied as in previous designs. The image sizes are less than 0.24 arc-seconds across the field for the V, R and I spectral bands. The images sizes are less than 0.42 and 0.30 arc-seconds across the field for the B and Z bands. The images at the U band, not included during the optimization process, are less than 0.60 arc-seconds.

Throughput

The throughput at full field for the 3.5 and 4.0 degree designs are about 57% and 52%, assuming a central obstruction on the primary mirror of 4.8 m in diameter. The obscuration has not been optimized in terms of throughput at full field, but earlier design work is used to estimate the best obscuration is between 4.6 and 4.8 m in diameter, and throughput is relatively insensitive to obscuration in this region.

Given that the throughput at full field is 62% for the 3.0 degree design, one can calculate the increase in collecting efficiency as:

$$\begin{aligned} \text{3.5 deg design} &= [57\% / 62\%] \times [3.5 \text{ deg} / 3.0 \text{ deg}]^2 = 1.25 \times \\ \text{4.0 deg design} &= [52\% / 62\%] \times [4.0 \text{ deg} / 3.0 \text{ deg}]^2 = 1.49 \times \end{aligned}$$

Conclusions

A field angle of 3.0 degrees for the baseline design is a reasonable choice based on the results of the January design study and this current preliminary investigation. It appears likely that a 4.0 degree design cannot be achieved without extensively sacrificing image sizes at all spectral bands. The 3.5 degree design offers some hope that performance be preserved in the central V, R and I bands while sacrificing some performance in the B and U bands. However, this reduced imaging capability is achieved for an overall efficiency gain of only 25%. In addition to the reduced imaging performance, one has to fully understand the risks and increased cost, weight, size and degree of difficulty for the detector, lens elements and spectral filters. Clearly, we are at a point where final trade studies should be undertaken to assess the risks imposed by the 3.0 degree design. These studies could lead to a recommendation that the final field angle be slightly larger or smaller than 3.0 degrees.

Sincerely,
Lynn G. Seppala

Optical design for a field of view of 4.0 degrees

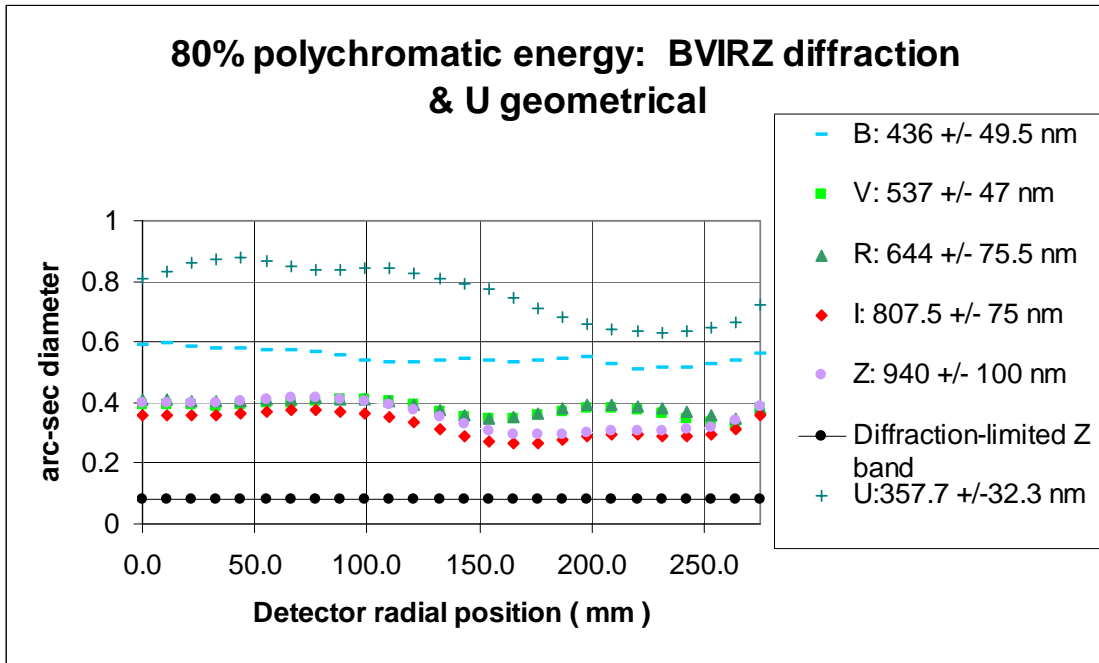

Design for 4.0 degrees full field of view

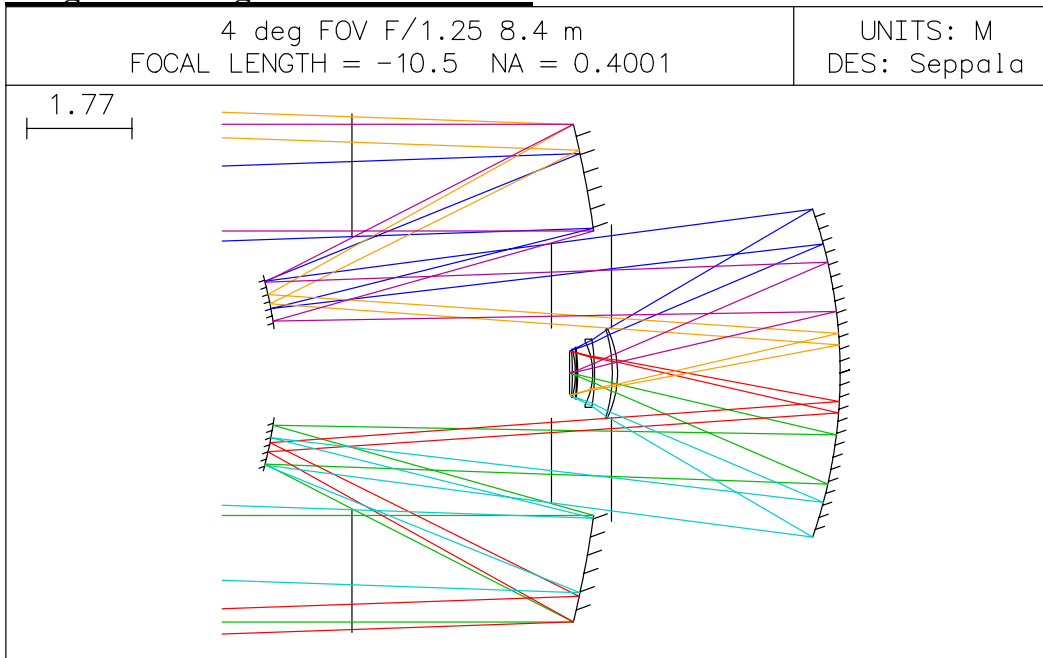

Obscuration is 4.8 m diameter for the 4.0 degree field of view

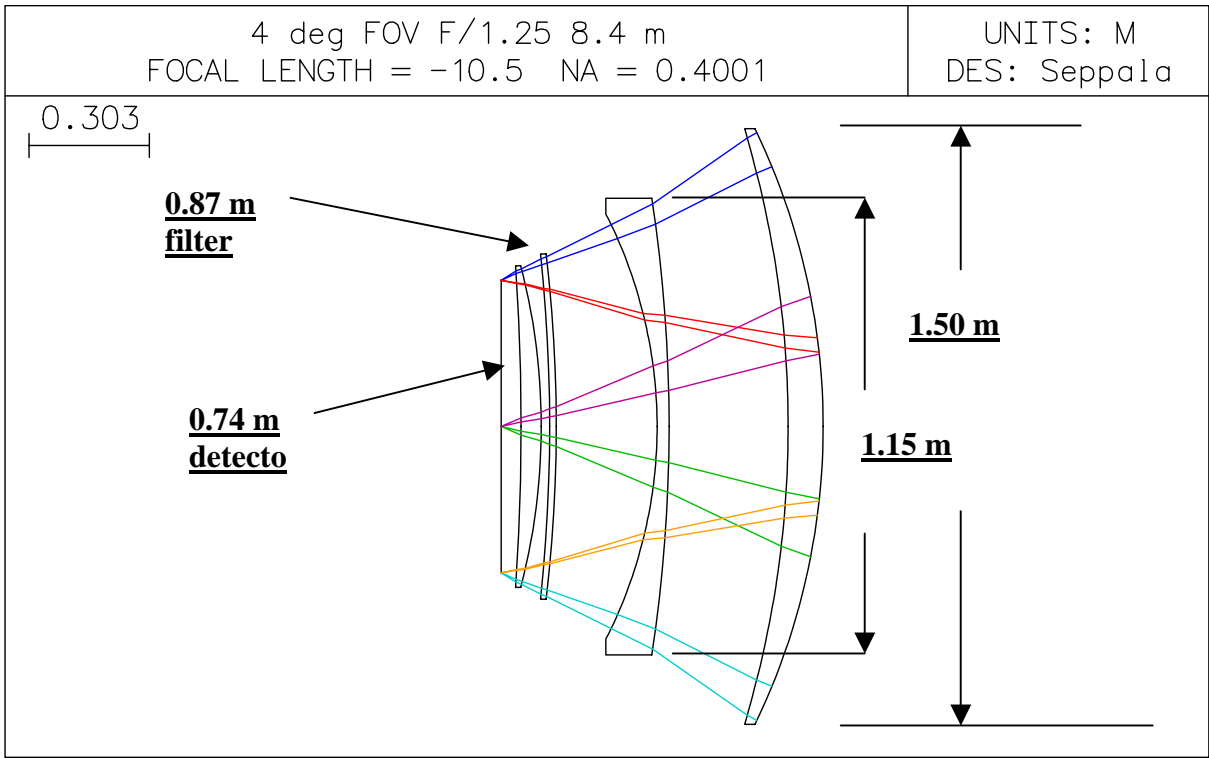

Lens L₁ is 1.5 m in diameter and detector is 0.74 m in diameter for a 4 degree field of view

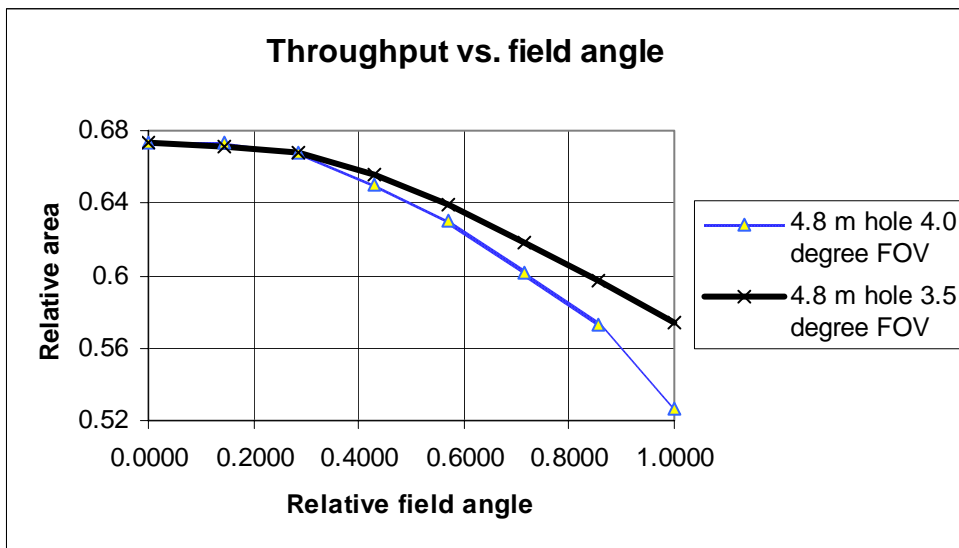

Comparison of throughput for obscuration of 4.8 m diameter for designs with 4.0 & 3.5 degree fields of view

The following pages list the lens data for the 6 spectral bands for the 4.0 degree design

*LENS DATA

CONFIGURATION 6

4 deg FOV F/1.25 8.4 m

SRF	RADIUS	THICKNESS	APERTURE RADIUS	GLASS	SPE	NOTE
OBJ	--	1.0638e+20	3.7150e+18	AIR		
1	--	1.265774	4.391930 S	AIR		
2	--	4.230388	4.368484 KX	AIR		outer baffle
AST	-17.363244	-4.230388 P	4.200000 AX	REFL_HATCH		* primary
4	--	-1.265774 P	2.305000 K	AIR		*
5	-6.032625	1.265774 P	1.650000 KX	REFL_HATCH		* secondary
6	--	3.355398	1.892077 S	AIR		
7	--	1.011291	2.190000 KX	AIR		inner baffle
8	--	3.846051	2.371149 KX	AIR		instrument obscuration
9	-8.492244	-3.746051 P	2.775000 K	REFL_HATCH		* tertiary
10	--	-0.000660	0.815200 S	AIR		
11	-1.728654	-0.088079	0.750000 K	SILICA		L1
12	-2.676176	-0.299608	0.750000 PK	AIR		*
13	--	0.003554	0.572874 S	AIR		
14	-3.836077	-0.030000	0.575000	SILICA C		L2
15	-1.146230	-0.253994	0.535000	AIR		*
16	--	-0.003554 P	0.436185 S	AIR		
17	-1.657385	-0.016700	0.435000	SILICA C		
18	-1.731724	-0.020959 P	0.435000 P	AIR		L3
19	-1.614133	-0.050868	0.405000	SILICA C		FILTER
20	-5.840170	-0.050000	0.405000 P	AIR		
IMS	--	--	0.370000			*

*WAVELENGTHS

CONFIGURATION 6

CURRENT	WV1/WW1	WV2/WW2	WV3/WW3	WV4/WW4	WV5/WW5
1	0.357700	0.325400	0.390000	0.341600	0.373900
	1.000000	1.000000	1.000000	1.000000	1.000000

*CONIC AND POLYNOMIAL ASPHERIC DATA

SRF	CC	AD	AE	AF	AG
3	-0.975909	--	4.9021e-09	--	--
5	-0.263492	--	-1.1568e-05	4.3534e-07	-1.1222e-07
9	-0.010284	--	5.5460e-07	9.8012e-09	--
12	3.410975	--	0.034922	0.004575	--
15	-0.911577	--	-0.064324	-0.272082	--

*LENS DATA

CONFIGURATION 2

4 deg FOV F/1.25 8.4 m

SRF OBJ	RADIUS	THICKNESS	APERTURE RADIUS	GLASS	SPE	NOTE
	--	1.0638e+20	3.7150e+18	AIR		
1	--	1.265774	4.391930 S	AIR		
2	--	4.230388	4.368484 KX	AIR		outer baffle
AST	-17.363244	-4.230388 P	4.200000 AX	REFL_HATCH		* primary
4	--	-1.265774 P	2.305000 K	AIR		*
5	-6.032625	1.265774 P	1.650000 KX	REFL_HATCH		* secondary
6	--	3.355398	1.892077 S	AIR		
7	--	1.011291	2.190000 KX	AIR		inner baffle
8	--	3.846051	2.371149 KX	AIR		instrument obscuration
9	-8.492244	-3.746051 P	2.775000 K	REFL_HATCH		* tertiary
10	--	-0.000330	0.815200 S	AIR		
11	-1.728654	-0.088079	0.750000 K	SILICA C		L1
12	-2.676176	-0.299608	0.750000 PK	AIR		*
13	--	0.001919	0.573511 S	AIR		
14	-3.836077	-0.030000	0.575000	SILICA C		L2
15	-1.146230	-0.253994	0.535000	AIR		*
16	--	-0.001919 P	0.435335 S	AIR		
17	-2.185670	-0.016700	0.435000	SILICA C		
18	-2.318318	-0.020959 P	0.435000 P	AIR		FILTER
19	-1.614133	-0.050868	0.405000	SILICA C		L3
20	-5.840170	-0.050000	0.405000 P	AIR		
IMS	--	--	0.370000			*

*WAVELENGTHS

CONFIGURATION 2

CURRENT	WV1/WW1	WV2/WW2	WV3/WW3	WV4/WW4	WV5/WW5
1	0.436000	0.386500	0.485500	0.411250	0.460750
	1.000000	1.000000	1.000000	1.000000	1.000000

*LENS DATA

CONFIGURATION 3

4 deg FOV F/1.25 8.4 m

SRF OBJ	RADIUS	THICKNESS	APERTURE RADIUS	GLASS	SPE	NOTE
	--	1.0638e+20	3.7150e+18	AIR		
1	--	1.265774	4.391930 S	AIR		
2	--	4.230388	4.368484 KX	AIR		outer baffle
AST	-17.363244	-4.230388 P	4.200000 AX	REFL_HATCH		* primary
4	--	-1.265774 P	2.305000 K	AIR		*
5	-6.032625	1.265774 P	1.650000 KX	REFL_HATCH		* secondary
6	--	3.355398	1.892077 S	AIR		
7	--	1.011291	2.190000 KX	AIR		inner baffle
8	--	3.846051	2.371149 KX	AIR		instrument obscuration
9	-8.492244	-3.746051 P	2.775000 K	REFL_HATCH		* tertiary
10	--	-9.8246e-05	0.815200 S	AIR		
11	-1.728654	-0.088079	0.750000 K	SILICA C		L1
12	-2.676176	-0.299608	0.750000 PK	AIR		*
13	--	0.000586	0.573954 S	AIR		
14	-3.836077	-0.030000	0.575000	SILICA C		L2
15	-1.146230	-0.253994	0.535000	AIR		*
16	--	-0.000586 P	0.434613 S	AIR		
17	-2.987468	-0.016700	0.435000	SILICA C		
18	-3.245901	-0.020959 P	0.435000 P	AIR		filter
19	-1.614133	-0.050868	0.405000	SILICA C		L3
20	-5.840170	-0.050000	0.405000 P	AIR		
IMS	--	--	0.370000			*

*WAVELENGTHS

CONFIGURATION 3

CURRENT	WV1/WW1	WV2/WW2	WV3/WW3	WV4/WW4	WV5/WW5
1	0.537000	0.490000	0.584000	0.513500	0.560500
	1.000000	1.000000	1.000000	1.000000	1.000000

*LENS DATA

4 deg FOV F/1.25 8.4 m

SRF OBJ	RADIUS	THICKNESS	APERTURE RADIUS	GLASS	SPE	NOTE
	--	1.0638e+20	3.7150e+18	AIR		
1	--	1.265774	4.391930 S	AIR		
2	--	4.230388	4.368484 KX	AIR		outer baffle
AST	-17.363244	-4.230388 P	4.200000 AX	REFL_HATCH		* primary
4	--	-1.265774 P	2.305000 K	AIR		*
5	-6.032625	1.265774 P	1.650000 KX	REFL_HATCH		* secondary
6	--	3.355398	1.892077 S	AIR		
7	--	1.011291	2.190000 KX	AIR		inner baffle
8	--	3.846051	2.371149 KX	AIR		instrument obscuration
9	-8.492244	-3.746051 P	2.775000 K	REFL_HATCH		* tertiary
10	--	--	0.815200 S	AIR		
11	-1.728654	-0.088079	0.750000 K	SILICA C		L1
12	-2.676176	-0.299608	0.750000 PK	AIR		*
13	--	--	0.574201 S	AIR		
14	-3.836077	-0.030000	0.575000	SILICA C		L2
15	-1.146230	-0.253994	0.535000	AIR		*
16	--	--	P 0.434308 S	AIR		
17	-3.730232	-0.016700	0.435000	SILICA C		
18	-4.147507	-0.020959 P	0.435000 P	AIR		FILTER
19	-1.614133	-0.050868	0.405000	SILICA C		
20	-5.840170	-0.050000	0.405000 P	AIR		L3
IMS	--	--	0.370000			*

*WAVELENGTHS

CURRENT	WV1/WW1	WV2/WW2	WV3/WW3	WV4/WW4	WV5/WW5
1	0.644000	0.569000	0.719000	0.606500	0.681500
	1.000000	1.000000	1.000000	1.000000	1.000000

*LENS DATA

CONFIGURATION 5

4 deg FOV F/1.25 8.4 m

SRF OBJ	RADIUS	THICKNESS	APERTURE RADIUS	GLASS	SPE	NOTE
	--	1.0638e+20	3.7150e+18	AIR		
1	--	1.265774	4.391930 S	AIR		
2	--	4.230388	4.368484 KX	AIR		outer baffle
AST	-17.363244	-4.230388 P	4.200000 AX	REFL_HATCH		* primary
4	--	-1.265774 P	2.305000 K	AIR		*
5	-6.032625	1.265774 P	1.650000 KX	REFL_HATCH		* secondary
6	--	3.355398	1.892077 S	AIR		
7	--	1.011291	2.190000 KX	AIR		inner baffle
8	--	3.846051	2.371149 KX	AIR		instrumentobscuration
9	-8.492244	-3.746051 P	2.775000 K	REFL_HATCH		* tertiary
10	--	0.000123	0.815200 S	AIR		
11	-1.728654	-0.088079	0.750000 K	SILICA		L1
12	-2.676176	-0.299608	0.750000 PK	AIR		*
13	--	-0.000885	0.574447 S	AIR		
14	-3.836077	-0.030000	0.575000	SILICA C		L2
15	-1.146230	-0.253994	0.535000	AIR		*
16	--	0.000885 P	0.433808 S	AIR		
17	-5.696946	-0.016700	0.435000	SILICA C		
18	-6.727167	-0.020959 P	0.435000 P	AIR		FILTER
19	-1.614133	-0.050868	0.405000	SILICA C		L3
20	-5.840170	-0.050000	0.405000 P	AIR		
IMS	--	--	0.370000			*

*WAVELENGTHS

CONFIGURATION 5

CURRENT	WV1/WW1	WV2/WW2	WV3/WW3	WV4/WW4	WV5/WW5
1	0.807500	0.732500	0.882500	0.770000	0.845000
	1.000000	1.000000	1.000000	1.000000	1.000000

*LENS DATA

CONFIGURATION 4

4 deg FOV F/1.25 8.4 m

SRF	RADIUS	THICKNESS	APERTURE RADIUS	GLASS	SPE	NOTE
OBJ	--	1.0638e+20	3.7150e+18	AIR		
1	--	1.265774	4.391930 S	AIR		
2	--	4.230388	4.368484 KX	AIR		outer baffle
AST	-17.363244	-4.230388 P	4.200000 AX	REFL_HATCH		* primary
4	--	-1.265774 P	2.305000 K	AIR		*
5	-6.032625	1.265774 P	1.650000 KX	REFL_HATCH		* secondary
6	--	3.355398	1.892077 S	AIR		
7	--	1.011291	2.190000 KX	AIR		inner baffle
8	--	3.846051	2.371149 KX	AIR		instrument obscuration
9	-8.492244	-3.746051 P	2.775000 K	REFL_HATCH		* tertiary
10	--	0.000173	0.815200 S	AIR		
11	-1.728654	-0.088079	0.750000 K	SILICA C		L1
12	-2.676176	-0.299608	0.750000 PK	AIR		*
13	--	-0.001233	0.574576 S	AIR		
14	-3.836077	-0.030000	0.575000	SILICA C		L2
15	-1.146230	-0.253994	0.535000	AIR		*
16	--	0.001233 P	0.433620 S	AIR		
17	-7.485902	-0.016700	0.435000	SILICA C		
18	-9.384627	-0.020959 P	0.435000 P	AIR		FILTER
19	-1.614133	-0.050868	0.405000	SILICA C		L3
20	-5.840170	-0.050000	0.405000 P	AIR		
IMS	--	--	0.370000			*

*WAVELENGTHS

CONFIGURATION 4

CURRENT	WV1/WW1	WV2/WW2	WV3/WW3	WV4/WW4	WV5/WW5
1	0.940000	0.840000	1.040000	0.890000	0.990000
	1.000000	1.000000	1.000000	1.000000	1.000000

*ZOOM POSITION 1

*APERTURES

SRF	TYPE	APERTURE RADIUS
0	SPC	3.7150e+18
1	CMP	4.391930
2	SPC	4.368484 CHK

Special Aperture Group 0:

A	ATP	Ellipse	AAC	Transmit	AAN	--	
	AX1	-4.375000	AX2	4.375000	AY1	-4.375000	AY2 4.375000
B	ATP	Ellipse	AAC	Obstruct	AAN	--	
	AX1	-2.305000	AX2	2.305000	AY1	-2.305000	AY2 2.305000

3	SPC	4.200000						
	Special Aperture Group 0:							
A	ATP	Ellipse	AAC	Transmit	AAN	--		
	AX1	-4.200000	AX2	4.200000	AY1	-4.200000	AY2	4.200000
B	ATP	Ellipse	AAC	Obstruct	AAN	--		
	AX1	-2.400000	AX2	2.400000	AY1	-2.400000	AY2	2.400000
4	SPC	2.305000	CHK					
5	SPC	1.650000	CHK					
	Special Aperture Group 0:							
A	ATP	Ellipse	AAC	Transmit	AAN	--		
	AX1	-1.650000	AX2	1.650000	AY1	-1.650000	AY2	1.650000
B	ATP	Ellipse	AAC	Obstruct	AAN	--		
	AX1	-0.750000	AX2	0.750000	AY1	-0.750000	AY2	0.750000
6	CMP	1.892077						
7	SPC	2.190000	CHK					
	Special Aperture Group 0:							
A	ATP	Ellipse	AAC	Transmit	AAN	--		
	AX1	-2.190000	AX2	2.190000	AY1	-2.190000	AY2	2.190000
B	ATP	Ellipse	AAC	Obstruct	AAN	--		
	AX1	-0.760000	AX2	0.760000	AY1	-0.760000	AY2	0.760000
8	SPC	2.371149	CHK					
	Special Aperture Group 0:							
A	ATP	Ellipse	AAC	Transmit	AAN	--		
	AX1	-2.500000	AX2	2.500000	AY1	-2.500000	AY2	2.500000
B	ATP	Ellipse	AAC	Obstruct	AAN	--		
	AX1	-0.750000	AX2	0.750000	AY1	-0.750000	AY2	0.750000
9	SPC	2.775000	CHK					
10	CMP	0.815200						
11	SPC	0.750000	CHK					
12	PKP	0.750000	CHK					
13	CMP	0.574201						
14	SPC	0.575000						
15	SPC	0.535000						
16	CMP	0.434308						
17	SPC	0.435000						
18	PKP	0.435000						
19	SPC	0.405000						
20	PKP	0.405000						
21	SPC	0.370000						

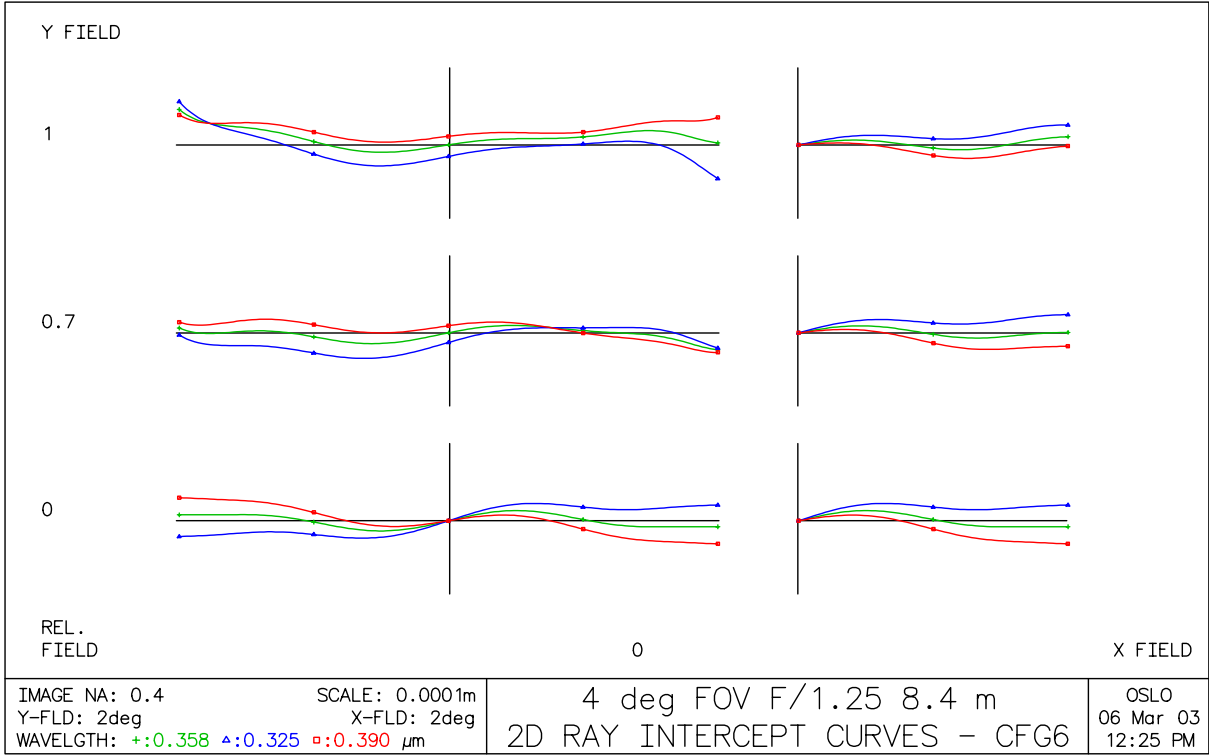

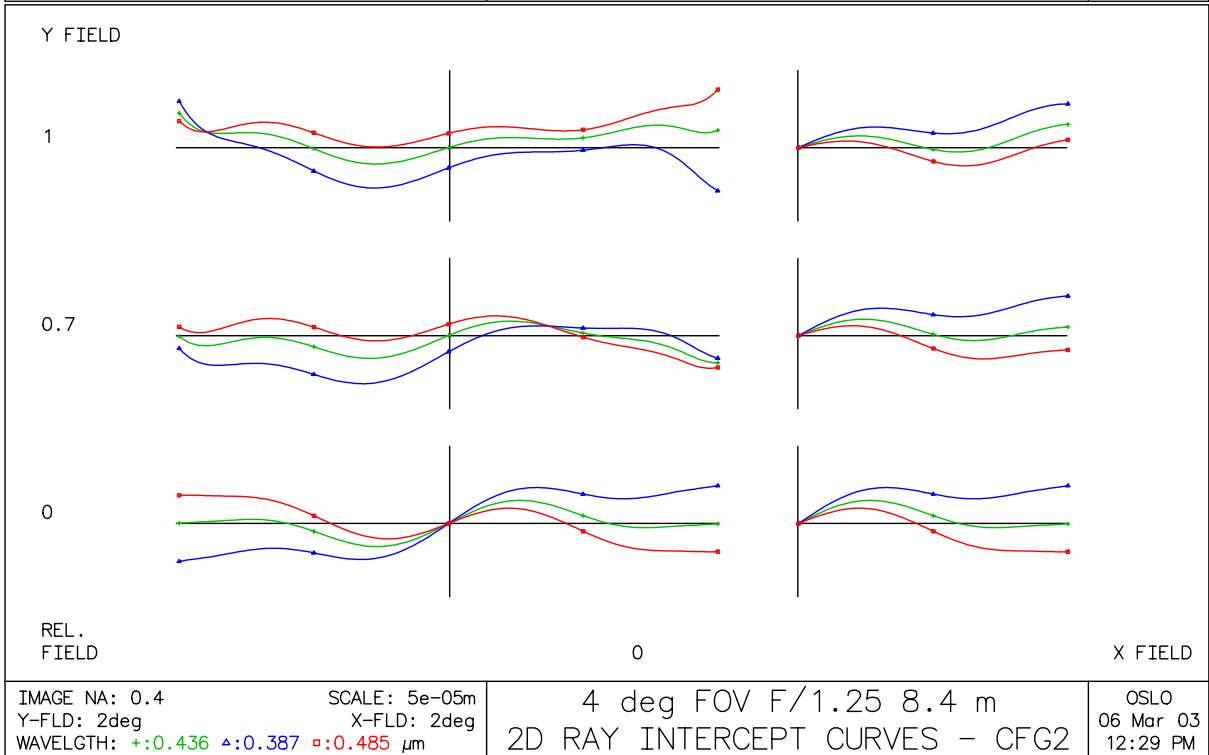
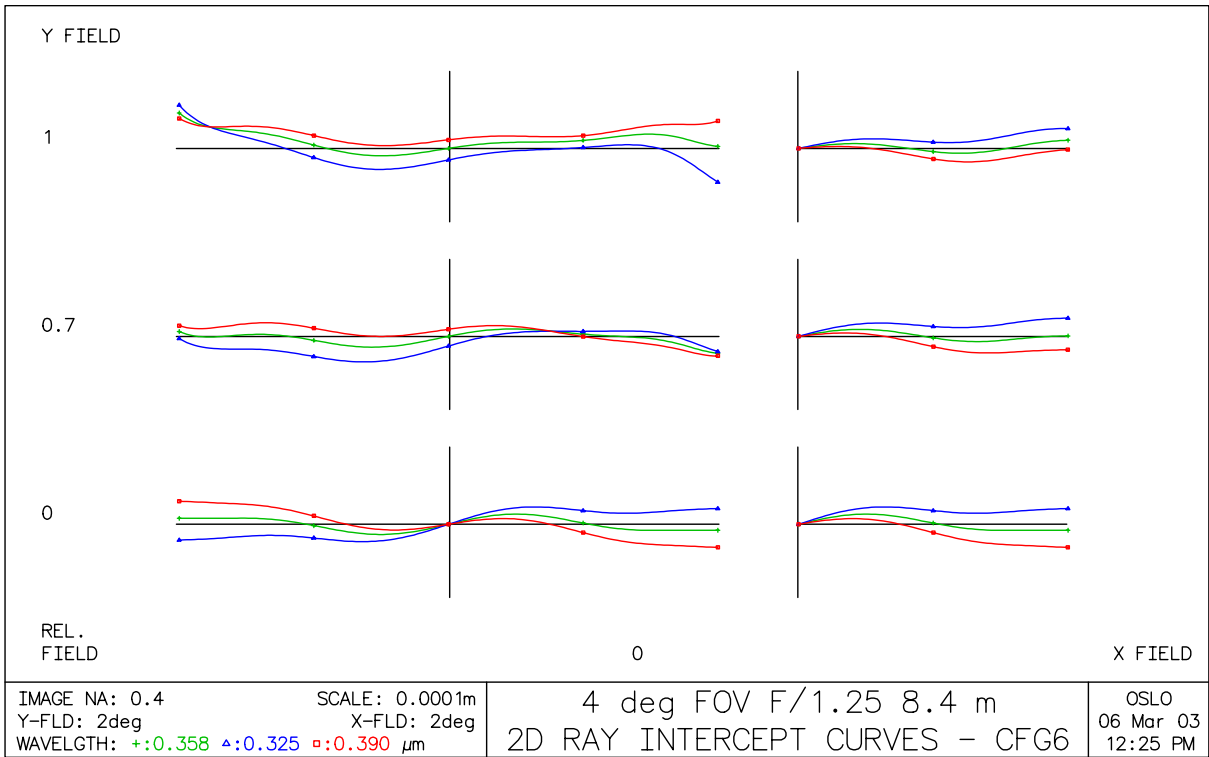

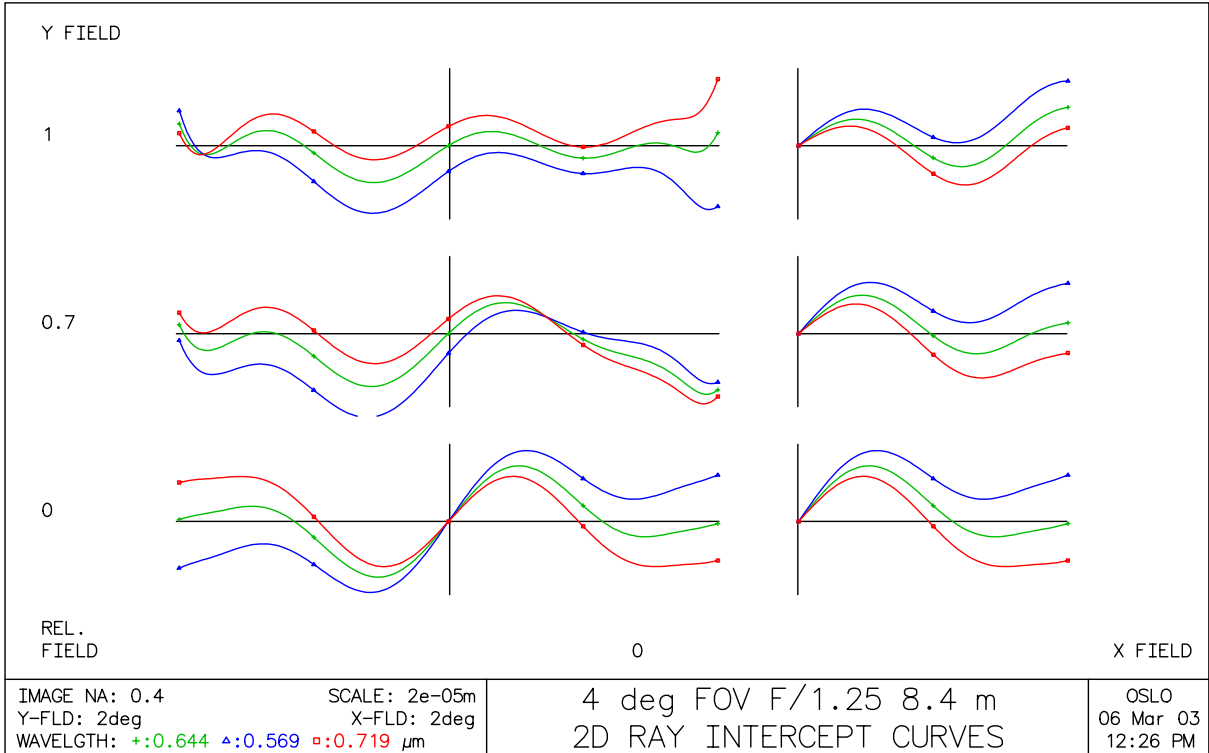
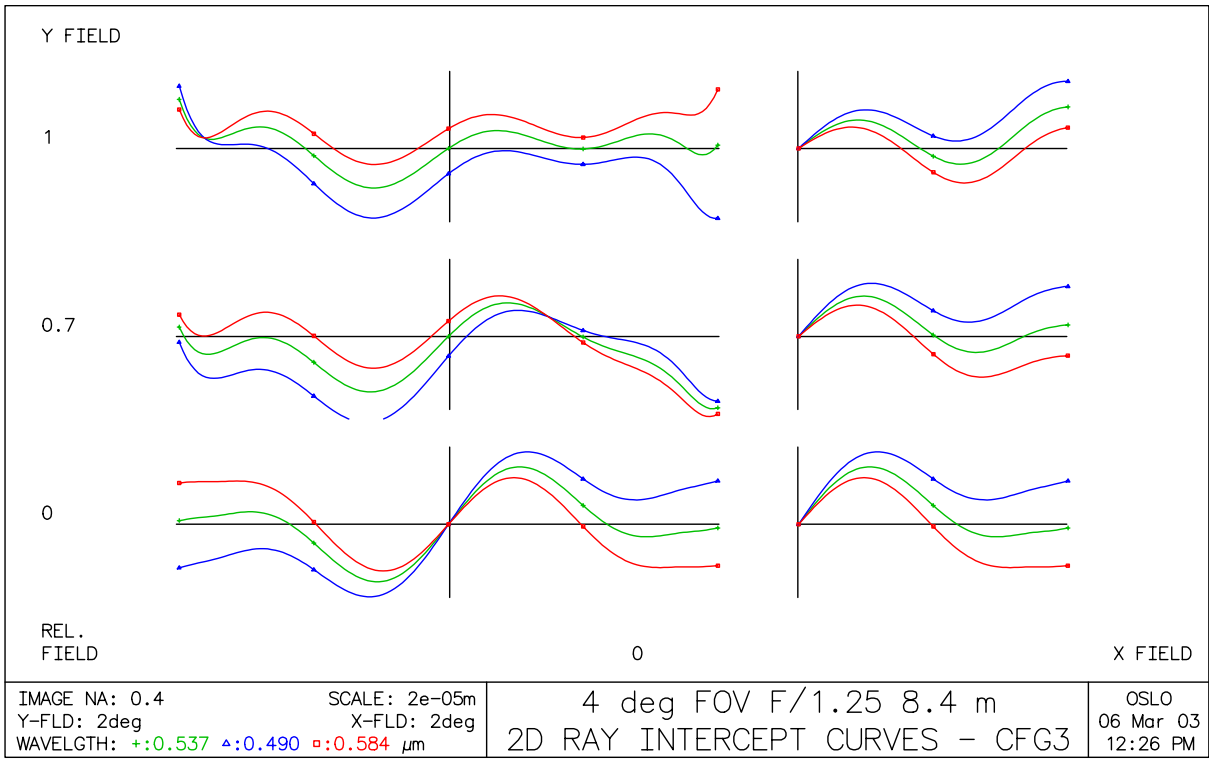

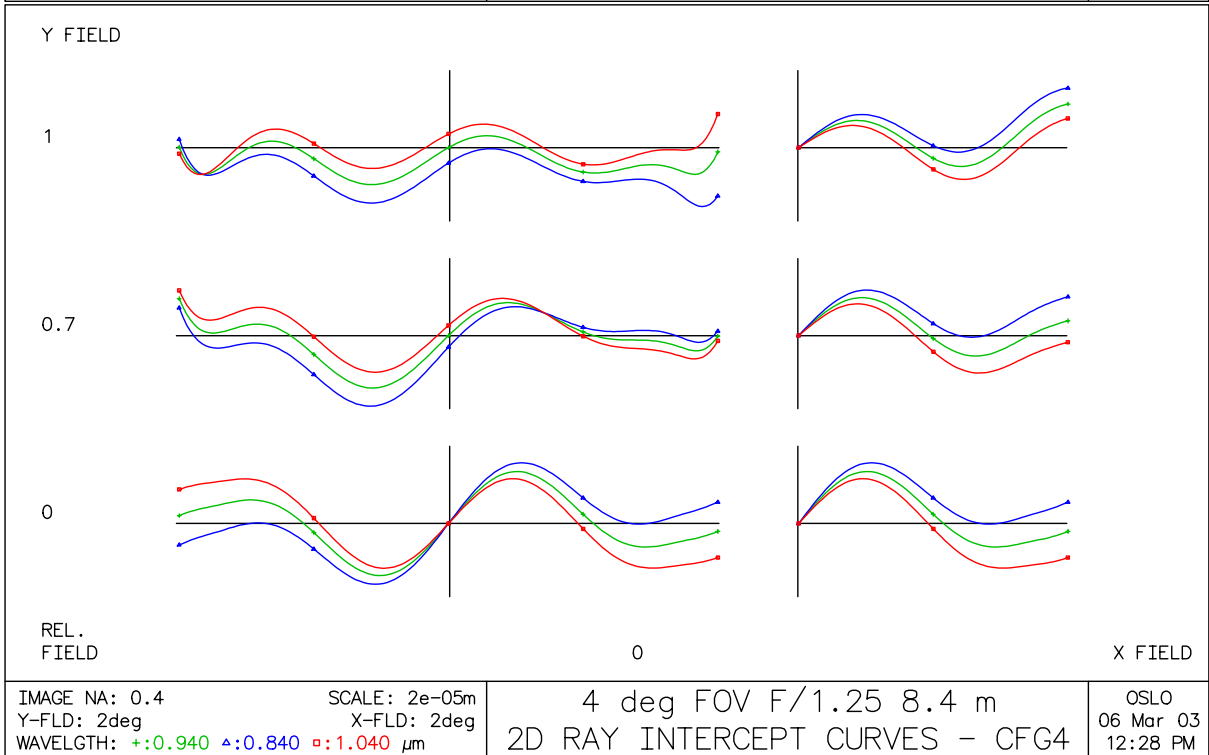
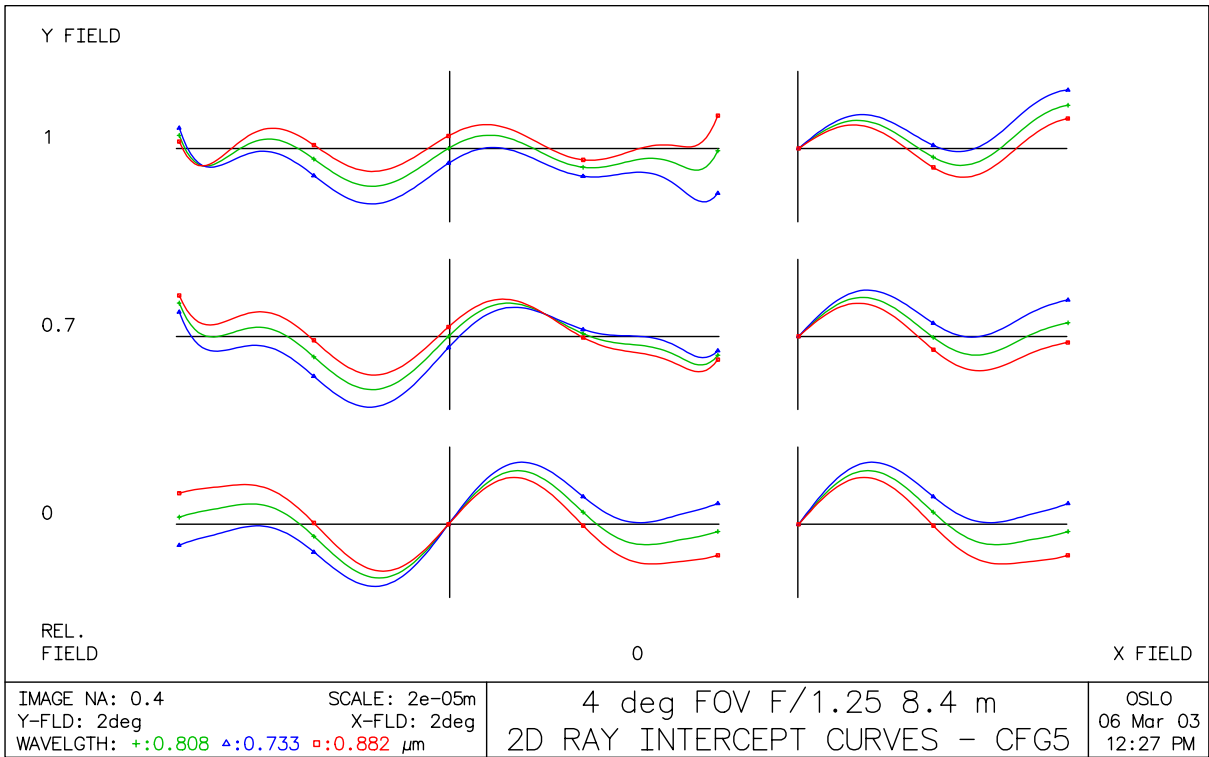

Design for 3.5 degrees full field of view

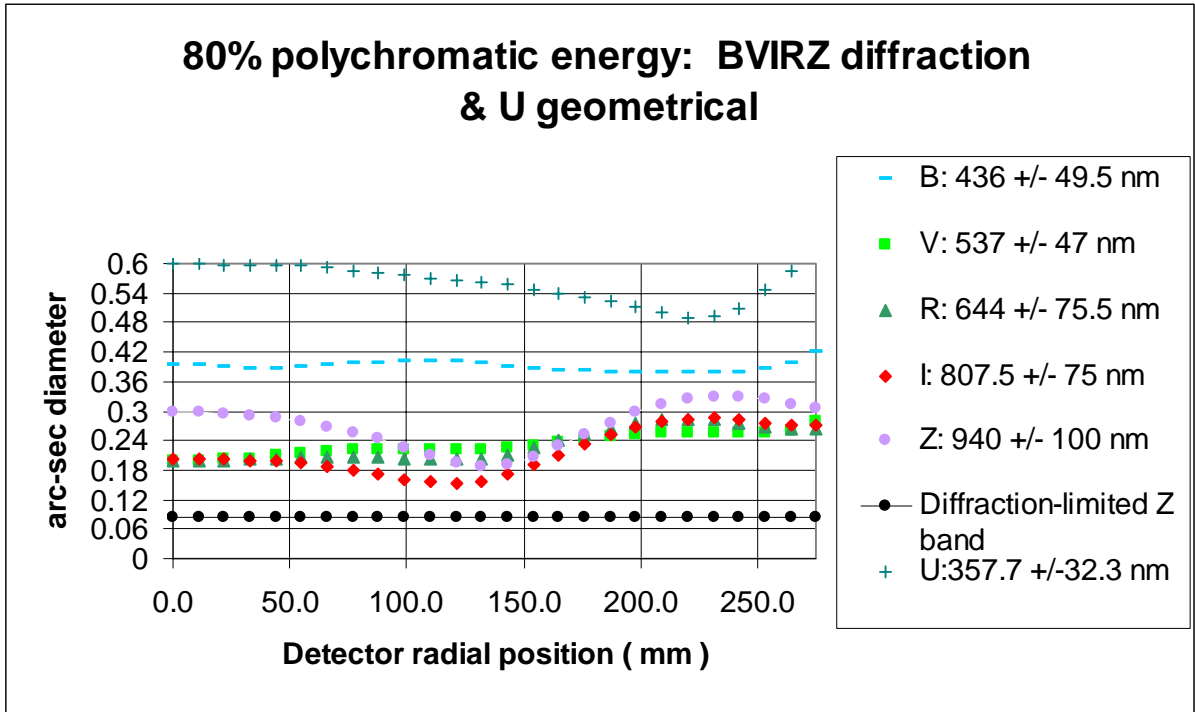

Design for 3.5 degrees full field of view

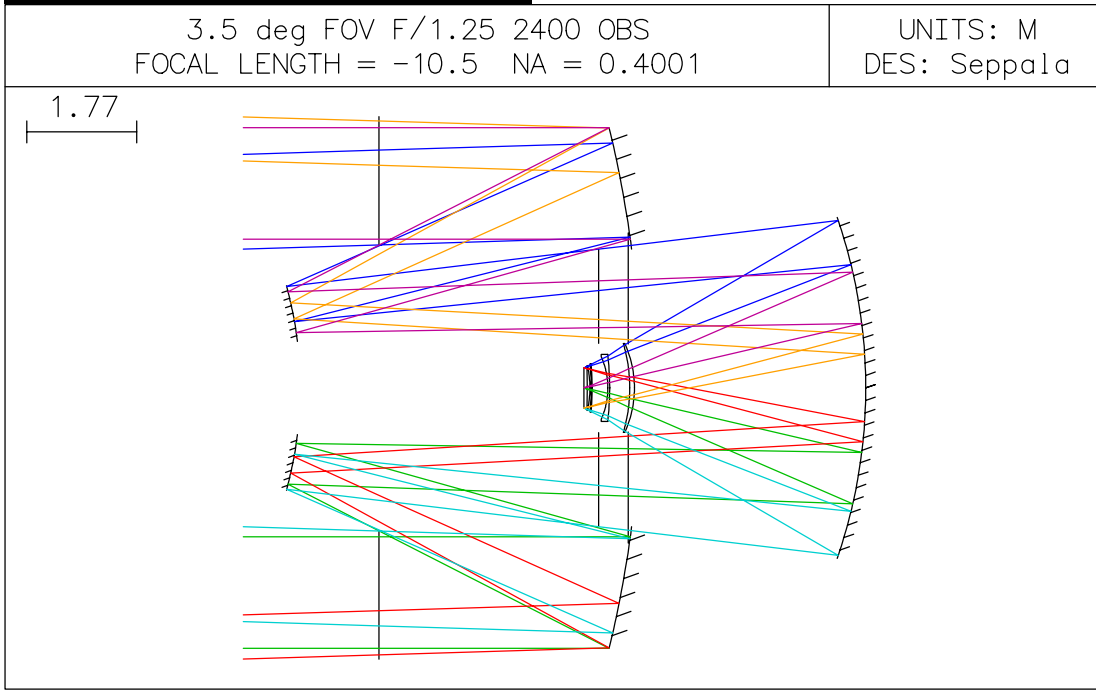

Obscuration is 4.8 m diameter for the 3.5 degree field of view

The following pages list the lens data for the 6 spectral bands for the 3.5 degree design

*LENS DATA

CONFIGURATION 6

3.5 deg FOV F/1.25 2400 OBS

SRF	RADIUS	THICKNESS	APERTURE RADIUS	GLASS	SPE	NOTE
OBJ	--	1.0000e+20	3.0553e+18	AIR		
1	--	1.266008	4.367194 S	AIR		
2	--	4.206284	4.368484 KX	AIR		outer baffle
AST	-17.408335	-4.206284	4.200000 AX	REFL_HATCH	*	primary
4	--	-1.266008 P	2.305000 K	AIR	*	
5	-6.135970	1.266008 P	1.650000 KX	REFL_HATCH	*	secondary
6	--	3.531328	1.866968 S	AIR		
7	--	0.476087	2.240000 KX	AIR		inner baffle
8	--	3.819029	2.371149 KX	AIR		instrument obscuration
9	-8.477644	-3.719029 P	2.750000 K	REFL_HATCH	*	tertiary
10	--	-0.002699	0.747465 S	AIR		
11	-1.724959	-0.076390	0.715000 K	SILICA C		L1
12	-2.582922	-0.321723	0.715000 K	AIR	*	
13	--	-0.000537	0.511586 S	AIR		
14	-4.591942	-0.030000	0.540000	SILICA		L2
15	-1.241267	-0.251247	0.510000	AIR	*	
16	--	0.000537 P	0.379241 S	AIR		
17	-4.078944	-0.025423	0.390000	SILICA C		FILTER
18	-4.008220	-0.012236 P	0.390000	AIR		corr_lens
19	-1.807493	-0.043061	0.360000	SILICA C		L3
20	-14.438840	-0.050000	0.360000	AIR		
IMS	--	--	0.322000		*	

*WAVELENGTHS

CONFIGURATION 6

CURRENT	WV1/WW1	WV2/WW2	WV3/WW3	WV4/WW4	WV5/WW5
1	0.357700	0.325400	0.390000	0.341600	0.373900
	1.000000	1.000000	1.000000	1.000000	1.000000

*CONIC AND POLYNOMIAL ASPHERIC DATA

CONFIGURATION 6

SRF	CC	AD	AE	AF	AG
3	-0.988822	--	3.3991e-09	--	--
5	-0.273973	--	-1.2226e-05	3.2506e-07	-1.0510e-07
9	0.018364	--	4.5178e-07	8.6323e-09	--
12	1.570523	--	0.019285	0.001823	--
15	-0.636557	--	-0.065659	-0.166554	--

*ZOOM POSITION 2

*LENS DATA

CONFIGURATION 2

3.5 deg FOV F/1.25 2400 OBS

SRF OBJ	RADIUS	THICKNESS	APERTURE RADIUS	GLASS	SPE	NOTE
	--	1.0000e+20	3.0553e+18	AIR		
1	--	1.266008	4.367194 S	AIR		
2	--	4.206284	4.368484 KX	AIR		OUTER BAFFLE
AST	-17.408335	-4.206284	4.200000 AX	REFL_HATCH		* primary
4	--	-1.266008 P	2.305000 K	AIR		*
5	-6.135970	1.266008 P	1.650000 KX	REFL_HATCH		* secondary
6	--	3.531328	1.866968 S	AIR		
7	--	0.476087	2.240000 KX	AIR		inner baffle
8	--	3.819029	2.371149 KX	AIR		instrument obscuration
9	-8.477644	-3.719029 P	2.750000 K	REFL_HATCH		* tertiary
10	--	-0.001349	0.747465 S	AIR		
11	-1.724959	-0.076390	0.715000 K	SILICA C		L1
12	-2.582922	-0.321723	0.715000 K	AIR		*
13	--	-0.000461	0.512699 S	AIR		
14	-4.591942	-0.030000	0.540000	SILICA C		L2
15	-1.241267	-0.251247	0.510000	AIR		*
16	--	0.000461 P	0.380126 S	AIR		
17	-4.078944	-0.021306	0.390000	SILICA C		
18	-4.051498	-0.016353 P	0.390000	AIR		FILTER
19	-1.807493	-0.043061	0.360000	SILICA C		L3
20	-14.438840	-0.050000	0.360000	AIR		
IMS	--	--	0.322000			*

*WAVELENGTHS

CONFIGURATION 2

CURRENT	WV1/WW1	WV2/WW2	WV3/WW3	WV4/WW4	WV5/WW5
1	0.436000	0.386500	0.485500	0.411250	0.460750
	1.000000	1.000000	1.000000	1.000000	1.000000

*ZOOM POSITION 3

*LENS DATA

CONFIGURATION 3

3.5 deg FOV F/1.25 2400 OBS

SRF	RADIUS	THICKNESS	APERTURE RADIUS	GLASS	SPE	NOTE
OBJ	--	1.0000e+20	3.0553e+18	AIR		
1	--	1.266008	4.367194 S	AIR		
2	--	4.206284	4.368484 KX	AIR		outer baffle
AST	-17.408335	-4.206284	4.200000 AX	REFL_HATCH		* primary
4	--	-1.266008 P	2.305000 K	AIR		*
5	-6.135970	1.266008 P	1.650000 KX	REFL_HATCH		* secondary
6	--	3.531328	1.866968 S	AIR		
7	--	0.476087	2.240000 KX	AIR		inner baffle
8	--	3.819029	2.371149 KX	AIR		instrument obscuration
9	-8.477644	-3.719029 P	2.750000 K	REFL_HATCH		* tertiary
10	--	-0.000507	0.747465 S	AIR		
11	-1.724959	-0.076390	0.715000 K	SILICA C		L1
12	-2.582922	-0.321723	0.715000 K	AIR		*
13	--	-0.000178	0.513422 S	AIR		
14	-4.591942	-0.030000	0.540000	SILICA C		L2
15	-1.241267	-0.251247	0.510000	AIR		*
16	--	0.000178 P	0.380838 S	AIR		
17	-4.078944	-0.018508	0.390000	SILICA C		FILTER
18	-4.065223	-0.019151 P	0.390000	AIR		
19	-1.807493	-0.043061	0.360000	SILICA C		L3
20	-14.438840	-0.050000	0.360000	AIR		
IMS	--	--	0.322000			*

*WAVELENGTHS

CONFIGURATION 3

CURRENT	WV1/WW1	WV2/WW2	WV3/WW3	WV4/WW4	WV5/WW5
1	0.537000	0.490000	0.584000	0.513500	0.560500
	1.000000	1.000000	1.000000	1.000000	1.000000

*ZOOM POSITION 1

*LENS DATA

3.5 deg FOV F/1.25 2400 OBS

SRF	RADIUS	THICKNESS	APERTURE	RADIUS	GLASS	SPE	NOTE
OBJ	--	1.0000e+20	3.0553e+18		AIR		
1	--	1.266008	4.367194	S	AIR		
2	--	4.206284	4.368484	KX	AIR		outer baffle
AST	-17.408335	-4.206284	4.200000	AX	REFL_HATCH		* primary
4	--	-1.266008	2.305000	K	AIR		*
5	-6.135970	1.266008	1.650000	KX	REFL_HATCH		* secondary
6	--	3.531328	1.866968	S	AIR		
7	--	0.476087	2.240000	KX	AIR		inner baffle
8	--	3.819029	2.371149	KX	AIR		instrument obscuration
9	-8.477644	-3.719029	2.750000	K	REFL_HATCH		* tertiary
10	--	--	0.747465	S	AIR		
11	-1.724959	-0.076390	0.715000	K	SILICA C		L1
12	-2.582922	-0.321723	0.715000	K	AIR		*
13	--	--	0.513860	S	AIR		
14	-4.591942	-0.030000	0.540000		SILICA C		L2
15	-1.241267	-0.251247	0.510000		AIR		*
16	--	--	0.381271	S	AIR		
17	-4.078944	-0.016808	0.390000		SILICA C		
18	-4.078944	-0.020851	0.390000	P	AIR		FILTER
19	-1.807493	-0.043061	0.360000		SILICA C		L3
20	-14.438840	-0.050000	0.360000		AIR		
IMS	--	--	0.322000				*

*WAVELENGTHS

CURRENT	WV1/WW1	WV2/WW2	WV3/WW3	WV4/WW4	WV5/WW5
1	0.644000	0.569000	0.719000	0.606500	0.681500
	1.000000	1.000000	1.000000	1.000000	1.000000

*ZOOM POSITION 5

*LENS DATA

CONFIGURATION 5

3.5 deg FOV F/1.25 2400 OBS

SRF OBJ	RADIUS	THICKNESS	APERTURE RADIUS	GLASS	SPE	NOTE
	--	1.0000e+20	3.0553e+18	AIR		
1	--	1.266008	4.367194 S	AIR		
2	--	4.206284	4.368484 KX	AIR		outer baffle
AST	-17.408335	-4.206284	4.200000 AX	REFL_HATCH		* primary
4	--	-1.266008 P	2.305000 K	AIR		*
5	-6.135970	1.266008 P	1.650000 KX	REFL_HATCH		* secondary
6	--	3.531328	1.866968 S	AIR		
7	--	0.476087	2.240000 KX	AIR		inner baffle
8	--	3.819029	2.371149 KX	AIR		instrument obscuration
9	-8.477644	-3.719029 P	2.750000 K	REFL_HATCH		* tertiary
10	--	0.000458	0.747465 S	AIR		
11	-1.724959	-0.076390	0.715000 K	SILICA C		L1
12	-2.582922	-0.321723	0.715000 K	AIR		*
13	--	0.000240	0.514260 S	AIR		
14	-4.591942	-0.030000	0.540000	SILICA C		L2
15	-1.241267	-0.251247	0.510000	AIR		*
16	--	-0.000240 P	0.381715 S	AIR		
17	-4.078944	-0.015217	0.390000	SILICA C		FILTER
18	-4.091622	-0.022443 P	0.390000	AIR		
19	-1.807493	-0.043061	0.360000	SILICA C		L3
20	-14.438840	-0.050000	0.360000	AIR		
IMS	--	--	0.322000			*

*WAVELENGTHS

CONFIGURATION 5

CURRENT	WV1/WW1	WV2/WW2	WV3/WW3	WV4/WW4	WV5/WW5
1	0.807500	0.732500	0.882500	0.770000	0.845000
	1.000000	1.000000	1.000000	1.000000	1.000000

*ZOOM POSITION 4

*LENS DATA

CONFIGURATION 4

3.5 deg FOV F/1.25 2400 OBS

SRF	RADIUS	THICKNESS	APERTURE RADIUS	GLASS	SPE	NOTE
OBJ	--	1.0000e+20	3.0553e+18	AIR		
1	--	1.266008	4.367194 S	AIR		
2	--	4.206284	4.368484 KX	AIR		outer baffle
AST	-17.408335	-4.206284	4.200000 AX	REFL_HATCH	*	primary
4	--	-1.266008 P	2.305000 K	AIR	*	
5	-6.135970	1.266008 P	1.650000 KX	REFL_HATCH	*	secondary
6	--	3.531328	1.866968 S	AIR		
7	--	0.476087	2.240000 KX	AIR		inner baffle
8	--	3.819029	2.371149 KX	AIR		instrument obscuration
9	-8.477644	-3.719029 P	2.750000 K	REFL_HATCH	*	tertiary
10	--	0.000691	0.747465 S	AIR		
11	-1.724959	-0.076390	0.715000 K	SILICA C		L1
12	-2.582922	-0.321723	0.715000 K	AIR	*	
13	--	0.000265	0.514473 S	AIR		
14	-4.591942	-0.030000	0.540000	SILICA C		L2
15	-1.241267	-0.251247	0.510000	AIR	*	
16	--	-0.000265 P	0.381879 S	AIR		
17	-4.078944	-0.014500	0.390000	SILICA C		
18	-4.105339	-0.023159 P	0.390000	AIR		FILTER
19	-1.807493	-0.043061	0.360000	SILICA C		
20	-14.438840	-0.050000	0.360000	AIR		L3
IMS	--	--	0.322000		*	

*WAVELENGTHS

CONFIGURATION 4

CURRENT	WV1/WW1	WV2/WW2	WV3/WW3	WV4/WW4	WV5/WW5
1	0.940000	0.840000	1.040000	0.890000	0.990000
	1.000000	1.000000	1.000000	1.000000	1.000000

*APERTURES

SRF TYPE APERTURE RADIUS

0	SPC	3.0553e+18	
1	CMP	4.367194	
2	SPC	4.368484	CHK

Special Aperture Group 0:

A ATP Ellipse AAC Transmit AAN --

	AX1	-4.375000	AX2	4.375000	AY1	-4.375000	AY2	4.375000
B	ATP	Ellipse	AAC	Obstruct	AAN	--		
	AX1	-2.305000	AX2	2.305000	AY1	-2.305000	AY2	2.305000
3	SPC	4.200000						
	Special Aperture Group 0:							
A	ATP	Ellipse	AAC	Transmit	AAN	--		
	AX1	-4.200000	AX2	4.200000	AY1	-4.200000	AY2	4.200000
B	ATP	Ellipse	AAC	Obstruct	AAN	--		
	AX1	-2.240000	AX2	2.240000	AY1	-2.240000	AY2	2.240000
4	SPC	2.305000	CHK					
5	SPC	1.650000	CHK					
	Special Aperture Group 0:							
A	ATP	Ellipse	AAC	Transmit	AAN	--		
	AX1	-1.650000	AX2	1.650000	AY1	-1.650000	AY2	1.650000
B	ATP	Ellipse	AAC	Obstruct	AAN	--		
	AX1	-0.750000	AX2	0.750000	AY1	-0.750000	AY2	0.750000
6	CMP	1.866968						
7	SPC	2.240000	CHK					
	Special Aperture Group 0:							
A	ATP	Ellipse	AAC	Transmit	AAN	--		
	AX1	-2.240000	AX2	2.240000	AY1	-2.240000	AY2	2.240000
B	ATP	Ellipse	AAC	Obstruct	AAN	--		
	AX1	-0.720000	AX2	0.720000	AY1	-0.720000	AY2	0.720000
8	SPC	2.371149	CHK					
	Special Aperture Group 0:							
A	ATP	Ellipse	AAC	Transmit	AAN	--		
	AX1	-2.500000	AX2	2.500000	AY1	-2.500000	AY2	2.500000
B	ATP	Ellipse	AAC	Obstruct	AAN	--		
	AX1	-0.710000	AX2	0.710000	AY1	-0.710000	AY2	0.710000
9	SPC	2.750000	CHK					
10	CMP	0.747465						
11	SPC	0.715000	CHK					
12	SPC	0.715000	CHK					
13	CMP	0.513860						
14	SPC	0.540000						
15	SPC	0.510000						
16	CMP	0.381271						
17	SPC	0.390000						
18	SPC	0.390000						
19	SPC	0.360000						
20	SPC	0.360000						
21	SPC	0.322000						

